

Smartsyn® FA-SOLVER®

BUILT-IN RESOLVERS
SHAFT RESOLVERS
HOLLOW SHAFT RESOLVERS



BRUSHLESS RESOLVERS

MEET YOUR NEEDS IN MOTION CONTROL APPLICATIONS

Wide Range of Built-in types
for Direct Mounting onto Motors

Smartsyn, and brushless resolvers, are to offer you highly enhanced reliability which has been enabled by excluding human-dependent works in the major production / inspection procedures from parts processing, assembling to shipping.

We'd like to offer the resolvers for such applications as follows.

- Commutation of brushless motors
- Feedback sensor of servo systems
- Robots
- Machine tools
- Aerospace servo systems
- Others where harsh environmental condition is involved

Smartsyn is a name of our brushless resolvers of a new type. They have their inherent characteristics as a resolver : maintenance-free brushless design, immunity to noise, vibration, shock, and high temperature.

And now they have more to offer : homogeneity in the ever-variable parameters like accuracy, transformation ratio, phase shift, etc., which has been realized by highly automated production. Now this new quality can be taken for granted.



FEATURES

- Wide Operating Temperature Range
 - 55 to +155°C (Built-in type)
 - 30 to +100°C (All Shaft types, TS2028, and TS2054)
- Usable in Demanding Environments
 - Vibration : 196m/s² {20G} at 10~500Hz
 - Shock : 981m/s² {100G} for 11ms
 - Humidity : 90% Rh Min. at 60°C
- High reliability and long life owing to brushlessness
- Operating speed up to :
 - 100~500s⁻¹ {6000~30000min⁻¹} / (Built-in type)
 - 100s⁻¹ {6000min⁻¹} / (Shaft type)
- Free from electrical and mechanical noise

MOUNTING REQUIREMENTS

The following mounting requirements should be kept to satisfy the specifications.

- Shaft Run-out
A motor shaft on which Rotor is mounted should have a run-out less than 0.050mm (TIR).
- Concentricity
Centers of resolver and motor shaft should be aligned within 0.050mm (TIR).
- Perpendicularity
Resolver case should be perpendicular to the motor shaft within 0.050mm (TIR).
- Axial Alignment
For built-in types, Stator and Rotor should be axially aligned within the tolerance of MTG.DIM.

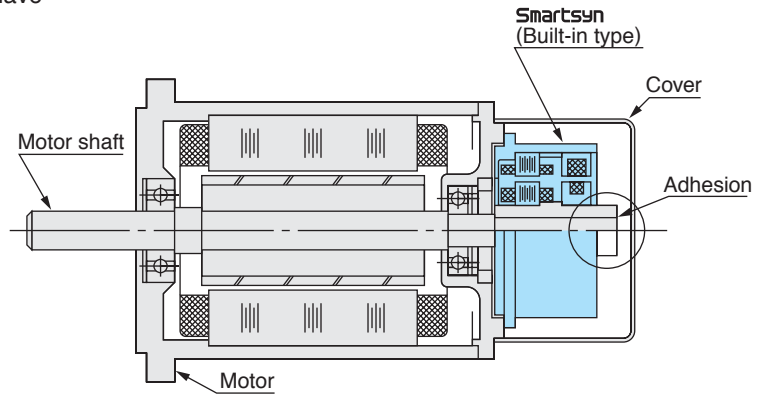

PRINCIPLE

Resolver is a rotary transformer, which outputs AC voltage in accordance with angular position of the shaft. There are two types of resolvers, BRX and BRT, having different types of winding.

BRX resolver is excited by AC voltage to the rotor winding, and outputs from the stator windings sine and cosine voltages proportion to the rotation angle θ .

BRT resolver is excited by sine and cosine voltages to the stator windings, and outputs from the rotor winding a sine voltage phase-shifted in proportion to θ .

The difference is illustrated as follows.

BRX

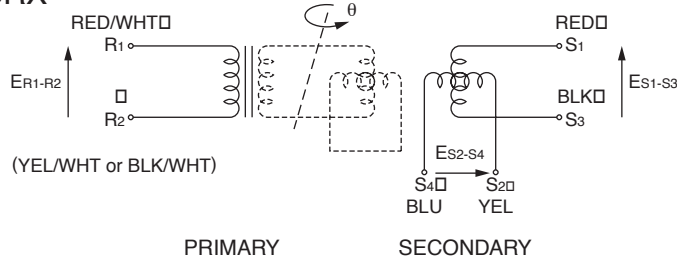

Excitation : $E_{R1-R2} = E \sin \omega t$

Output : $E_{S1-S3} = K E_{R1-R2} \cos \theta$

$E_{S2-S4} = K E_{R1-R2} \sin \theta$ (Normal Type)

$E_{S2-S4} = -K E_{R1-R2} \sin \theta$ (Reverse Type)

K : Transformation Ratio

BRT

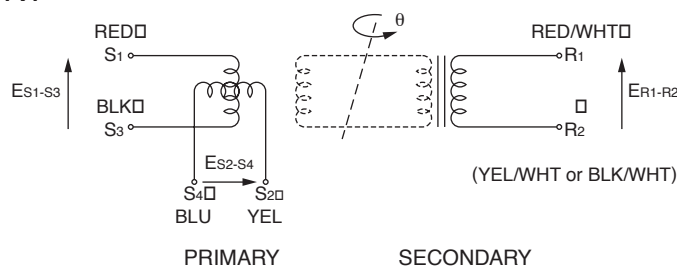

Excitation : $E_{S1-S3} = E \sin \omega t$

$E_{S2-S4} = E \cos \omega t$

Output : $E_{R1-R2} = K E_{S1-S3} \cos \theta - K E_{S2-S4} \sin \theta$
 $= K E \sin (\omega t - \theta)$ (Normal Type)

$E_{R1-R2} = K E_{S1-S3} \cos \theta + K E_{S2-S4} \sin \theta$
 $= K E \sin (\omega t + \theta)$ (Reverse Type)

K : Transformation Ratio

+ θ :CCW is positive when viewed from mounting end.

BUILT-IN RESOLVERS

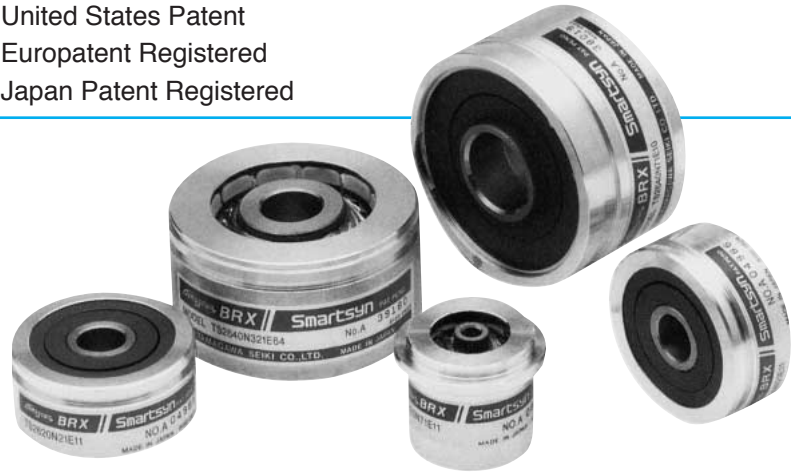

SIZE		08	10	15		21	
Model No.		TS2605N1E64	TS2610N171E64	TS2620N21E11	TS2620N271E14	TS2640N321E64	TS2640N691E125
Type		BRX	←	←	←	←	←
Primary		R1-R2	←	←	←	←	←
Input Voltage/Frequency		AC7Vrms 10kHz	AC7Vrms 10kHz	AC7Vrms 10kHz	AC10Vrms 4.5kHz	AC7Vrms 10kHz	AC5Vrms 4kHz
Transformation Ratio		0.5 ± 5%	0.5 ± 5%	0.5 ± 5%	0.5 ± 10%	0.5 ± 5%	0.5 ± 10%
Electrical Error		± 10' Max.	± 10' Max.	± 10' Max.	± 10' Max.	± 10' Max.	± 8' Max.
Residual Voltage		20mVrms Max.	←	←	←	←	—
Phase Shift		+10° Nom	+5° Nom.	0° REF	+8° Nom.	+1° Nom.	+0 ~ +10°
Impedance	Z _{Ro}	140 Ω ± 20%	160 Ω Nom.	70+j100 Ω Nom.	90+j180 Ω Nom.	100+j140 Ω ± 15%	290 Ω Nom.
	Z _{so}	—	160 Ω Nom.	180+j300 Ω Nom.	220+j350 Ω Nom.	140+j270 Ω ± 15%	—
	Z _{ss}	120 Ω ± 20%	130 Ω Nom.	175+j275 Ω Nom.	210+j300 Ω Nom.	120+j240 Ω ± 15%	420 Ω Nom.
Operating Temperature		-55 ~ +155°C	←	←	←	←	←
Max. Operating Speed		500s ⁻¹	166.6 ··· s ⁻¹	←	←	←	100s ⁻¹
Mass		0.03kg	0.04kg	0.065 kg Max.	0.18 kg Max.	0.28 kg Nom.	0.25 kg Nom.
Output Type <small>Rotor is CCW rotation viewed from mounting flange end</small>		Reverse CCW	←	Normal + θ CCW	←	←	←

OUTLINE

(DIMENSION : mm)

SIZE 08 TS2605N1E64

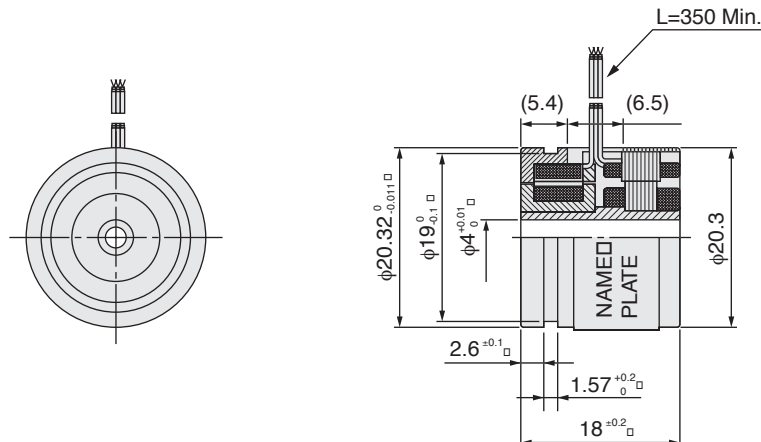

SIZE 10

TS2610N171E64

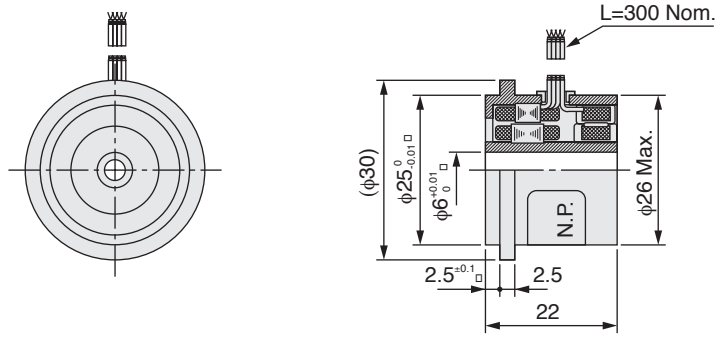

SIZE 15

TS2620N21E11

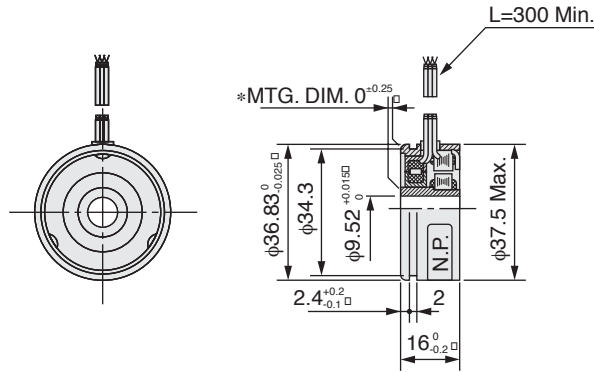

SIZE 15

TS2620N271E14

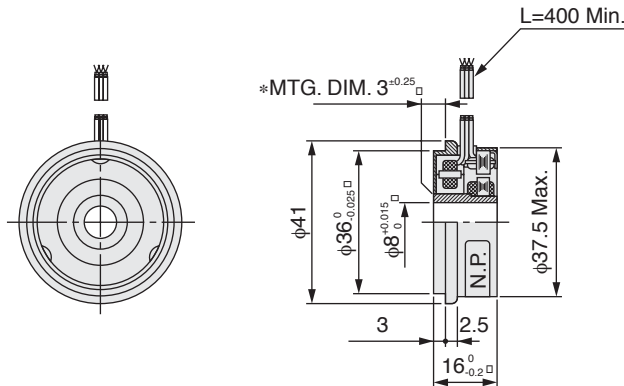

SIZE 21

TS2640N321E64

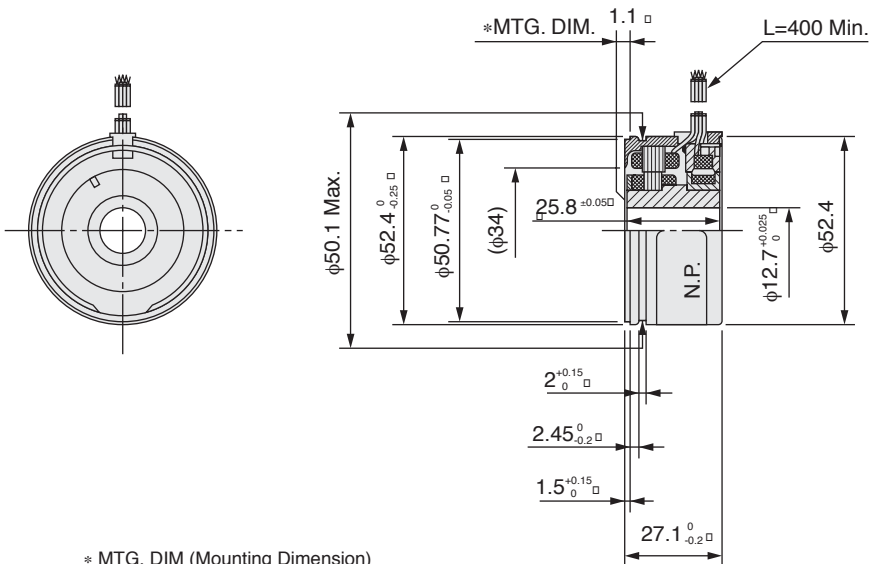

TS2640N691E125

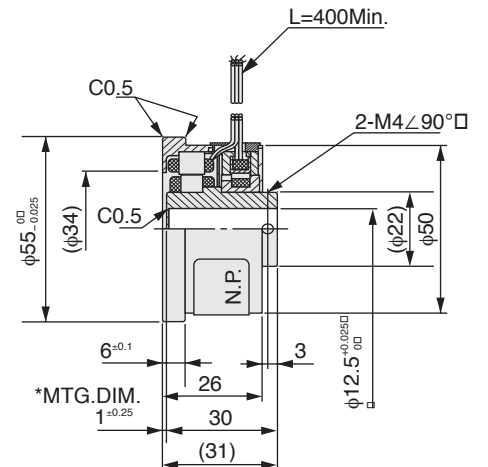

* MTG. DIM (Mounting Dimension)

FA-SOLVER®

BUILT-IN RESOLVERS



Products on this page are within FA-SOLVER® series.

SIZE	25	30	35	43	47	
Model No.	TS2013N191E26	TS2142N1E63	TS2158N21E63	TS2028N41E48	TS2054N91E51	
Type	BRX	←	←	←	←	
Primary	R1-R2	←	←	←	←	
Input Voltage/Frequency	AC10Vrms 4.5kHz	AC7Vrms 5kHz	AC10Vrms 5kHz	AC10Vrms 4.5kHz	AC6Vrms 10kHz	
Transformation Ratio	0.5 ± 5%	0.5 ± 10%	←	←	0.28 ± 10%	
Electrical Error	± 7' Max.	± 10' Max.	←	←	←	
Residual Voltage	—	20mVrms Max.	30mVrms Max.	←	20mVrms Max.	
Phase Shift	-10° Max.	-10° Nom.	-15° Nom.	←	-30° Nom.	
Impedance	Z _{RO}	280+j410 Ω Nom	100+j170 Ω Nom	176 Ω Nom	200 Ω Nom	260+j500 Ω Nom
	Z _{SO}	375+j575 Ω Nom.	—	—	—	—
	Z _{SS}	290+j510 Ω Nom.	200+j350 Ω Nom.	250 Ω Nom.	285 Ω Nom.	214+j338 Ω Nom.
Operating Temperature	-55 ~ +155°C	←	-40 ~ +150°C	-30 ~ +100°C	←	
Max. Operating Speed	166.6 ··· s ⁻¹	100s ⁻¹	←	←	166.6 ··· s ⁻¹	
Mass	0.35kg Nom.	1.0kg Max.	0.9kg Nom.	1.4 kg Nom.	1.6 kg Nom.	
Output Type Rotor is CCW rotation viewed from mounting flange end	Reverse + θ CCW	Normal + θ CCW	←	←	←	

OUTLINE

(DIMENSION : mm)

SIZE 25 TS2013N191E26

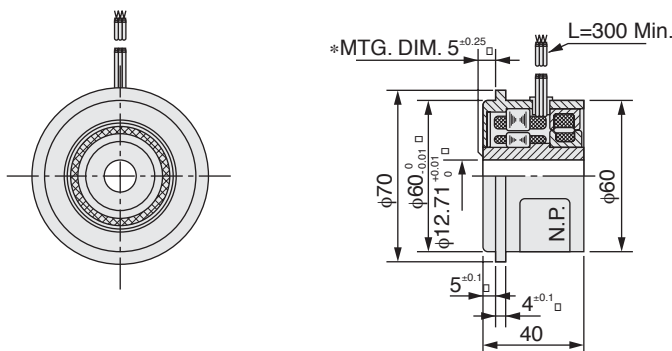

SIZE 30 TS2142N1E63

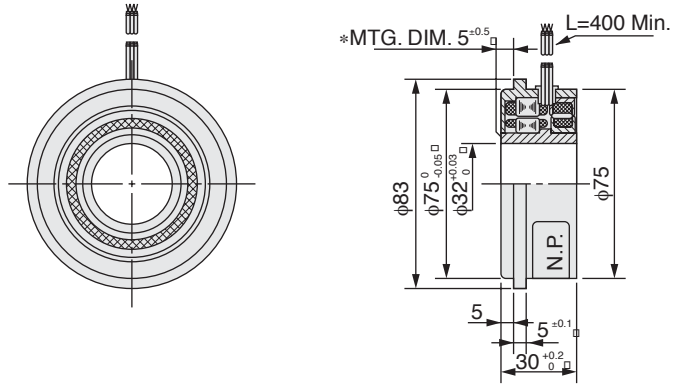

SIZE 35 TS2158N21E63

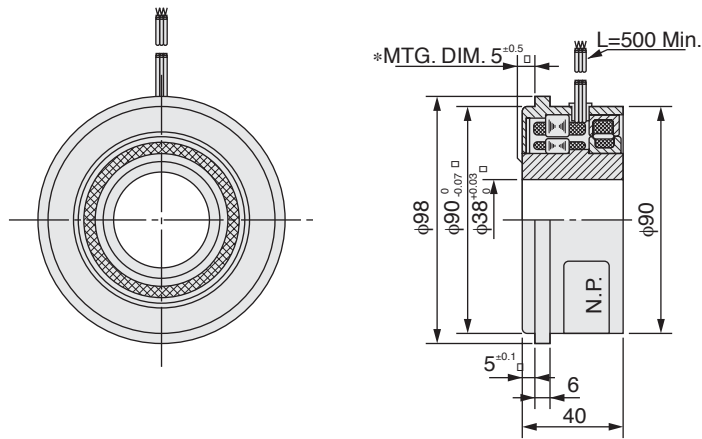

SIZE 43 TS2028N41E48

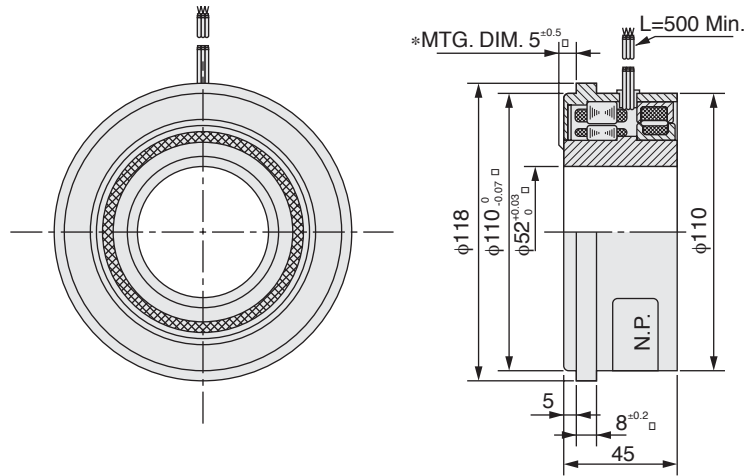

SIZE 47 TS2054N91E51

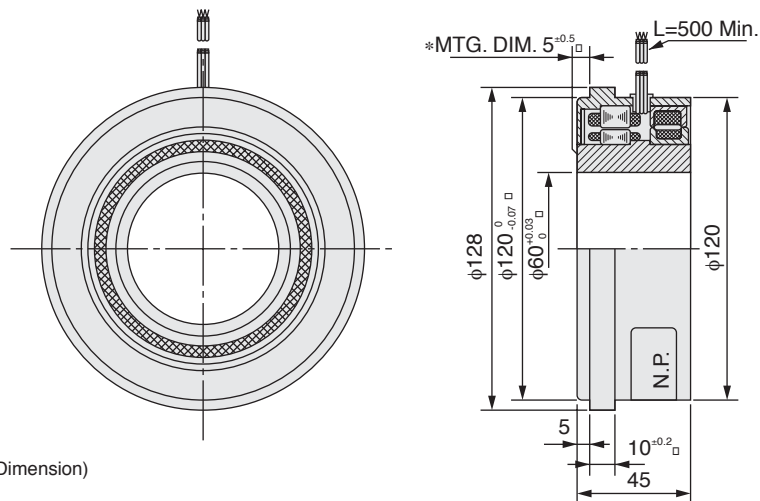

* MTG. DIM (Mounting Dimension)

FA-SOLVER®

SHAFT RESOLVERS BRX TYPE

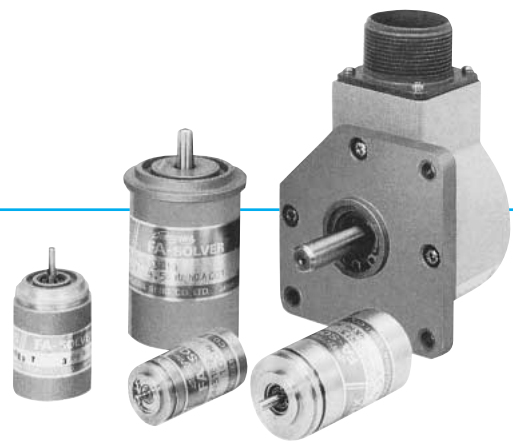

Products on this page are within FA-SOLVER® series.

SIZE		08	10	11	15	25
Model No.		TS510N35E18	TS520N46E9	TS530N33E10	TS540N33E12	TS2014N14E41
Type		BRX	←	←	←	←
Primary		R1-R2	←	←	←	←
Input Voltage/Frequency		AC7Vrms 3kHz	←	AC18Vrms 5kHz	AC15Vrms 1kHz	AC5.5Vrms 10kHz
Transformation Ratio		0.5 ± 10%	←	0.5 ± 20%	0.5 ± 10%	0.5 Nom.
Electrical Error		± 15' Max.	± 10' Max.	Spread10'	± 10' Max.	←
Residual Voltage		15mVrms Max.	←	←	20mVrms Max.	30mVrms Max.
Phase Shift		+9.5° Nom	+20° Max.	←	+5° Nom.	-20° Nom
Impedance	Z _{RO}	860+j1,230 Ω Nom.	700 Ω Min.	1,000 Ω	1,030 Ω Nom.	62+j79 Ω Ref.
	Z _{SO}	—	—	—	680 Ω Nom.	110+j220 Ω Ref.
	Z _{SS}	205+j190 Ω Nom.	250 Ω Nom.	—	540 Ω Nom.	90+j215 Ω Ref.
Operating Temperature		-55 ~ +125°C	-30 ~ +100°C	←	←	←
Max.Operating Speed		100s ⁻¹	←	83.3···s ⁻¹	100s ⁻¹	←
Mass		0.045kg Nom.	0.1kg Max.	0.15kg Max.	0.3kg Max.	0.62kg Nom.
Output Type <small>Rotor is CCW rotation viewed from mounting flange end.</small>		Normal + θ CCW	←	←	Reverse + θ CCW	Normal + θ CCW

OUTLINE

(DIMENSION : mm)

SIZE 08 TS510N35E18

SIZE 10 TS520N46E9

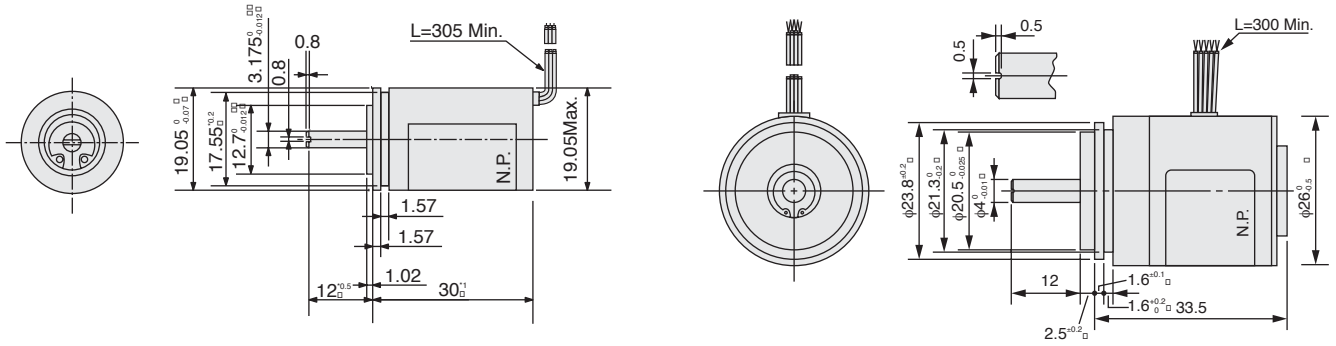

SIZE 11 TS530N33E10

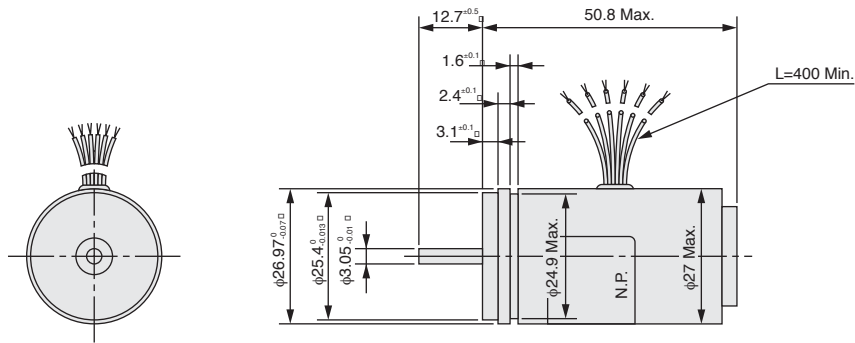

SIZE 15 TS540N33E12

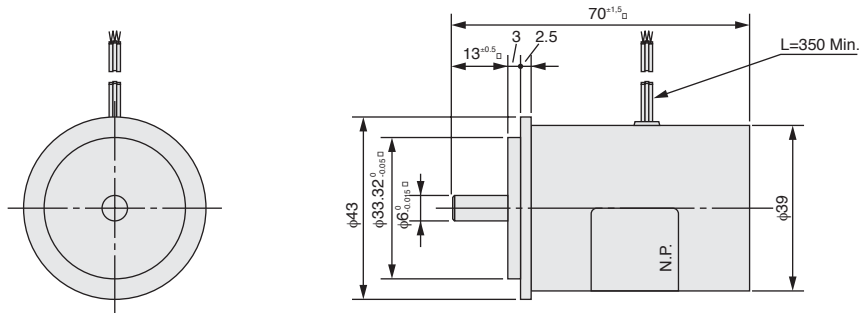

SIZE 25 TS2014N141E41

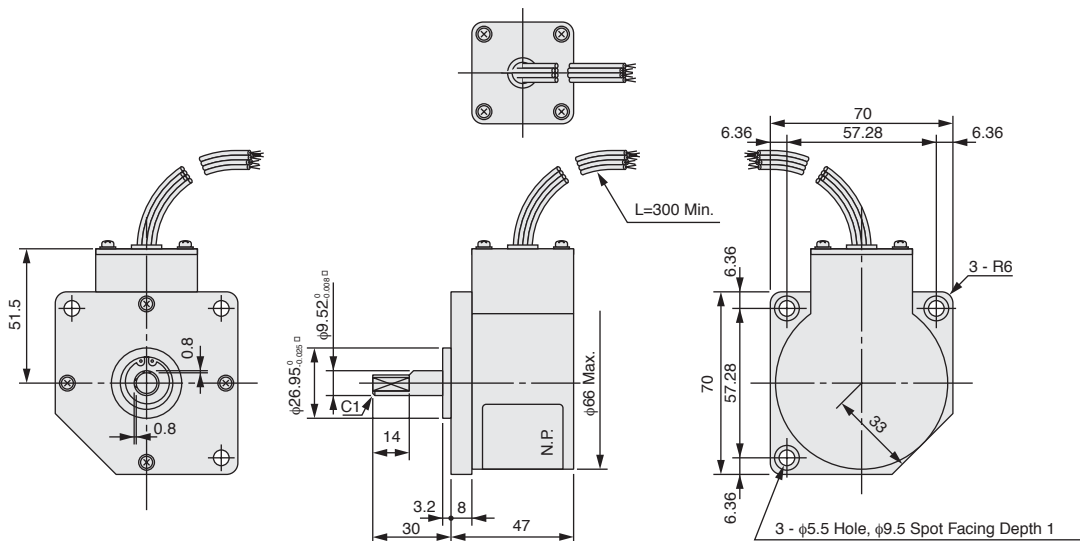

FA-SOLVER®

SHAFT RESOLVERS BRT TYPE

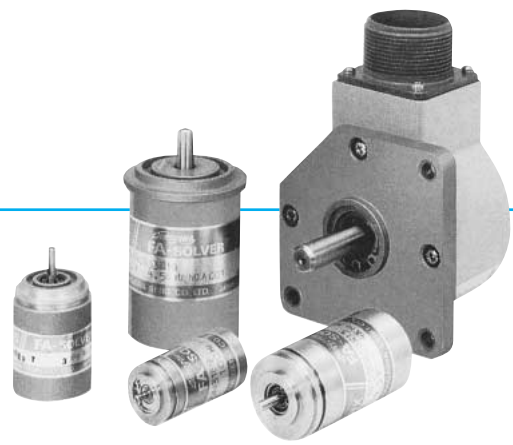

Products on this page are within FA-SOLVER® series.

SIZE		08	10	11	15	25
Model No.		TS510N48E30	TS520N45E11	TS530N33E9	TS540N33E10	TS2014N51E1
Type		BRT	←	←	←	←
Primary		S1-S3,S2-S4	←	←	←	←
Input Voltage/Frequency		AC12Vrms 2.5kHz	AC15Vrms 5kHz	AC3.5Vrms 3kHz	AC10Vrms 4.5kHz	AC10Vrms 4.5kHz
Transformation Ratio		0.5 ± 15%	0.55 Min.	0.56 ^{+8%} _{-6%}	0.5 Nom.	0.3 Nom.
Electrical Error		± 15' Max.	Spread10' Max.	Spread10' Max. (AT11.8Vrms/400Hz)	Spread10' Max	Spread15' Max
Impedance	Z _{SO}	800 Ω Nom.	3,600 Ω Ref.	500 Ω Min. (AT11.8Vrms/400Hz)	1600 Ω Nom.	1800 Ω Nom.
	Z _{RS}	120 Ω Nom.	80 Ω Ref.	1000 Ω Max. (AT11.8Vrms/400Hz)	1500 Ω Nom.	3800 Ω Nom.
Operating Temperature		-55 ~ +125°C	—	0 ~ +90°C	—	—
Max.Operating Speed		100s ⁻¹	←	133.3s ⁻¹	—	—
Mass		0.045kg Nom.	0.07kg Nom.	0.11kg	0.3kg Max.	0.62kg Nom.

OUTLINE

(DIMENSION : mm)

SIZE 08 TS510N48E30

SIZE 10 TS520N45E11

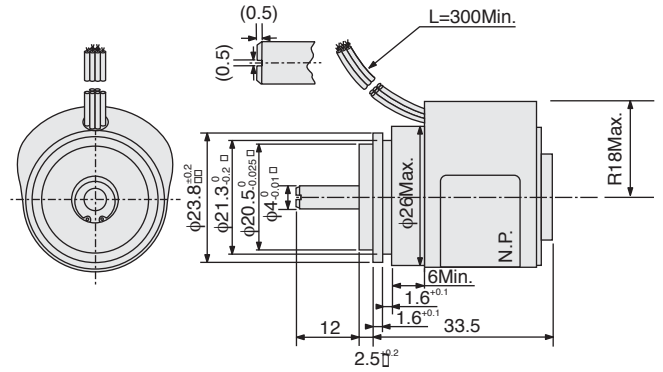
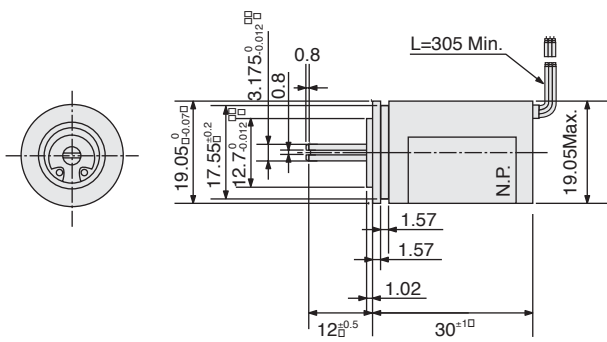

SIZE 11 TS530N33E9

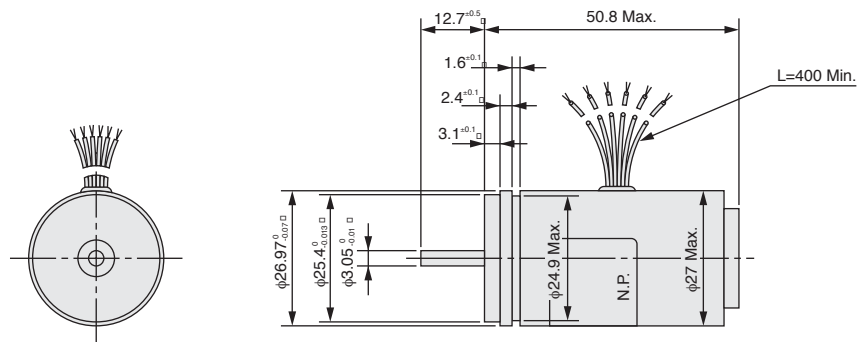

SIZE 15 TS540N33E10

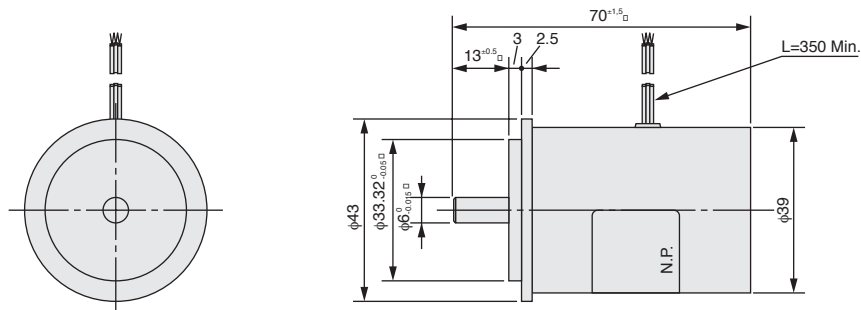

SIZE 25 TS2014N51E1

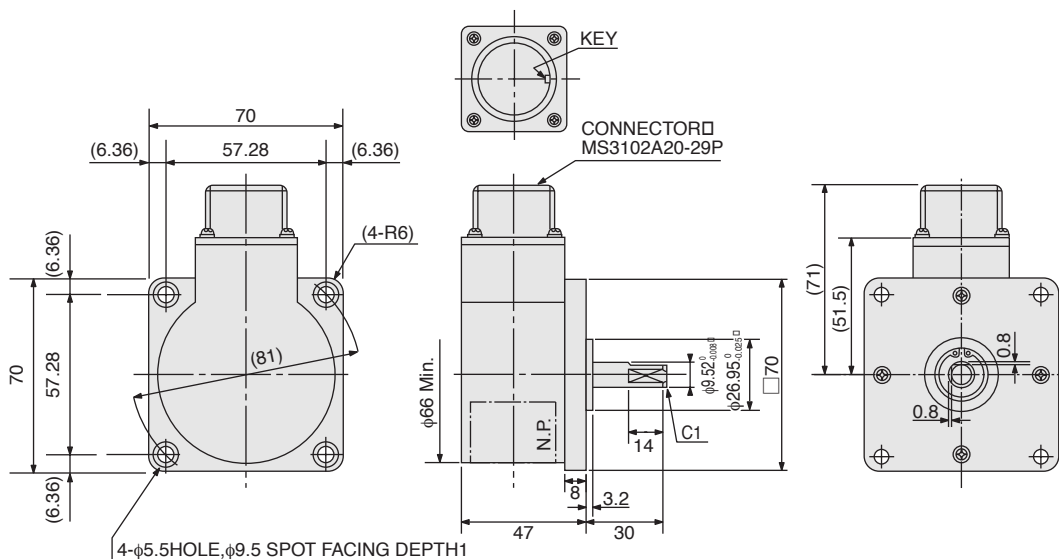



SIZE		10	21	
Model No.		TS2611N11E11	TS2641N11E64	TS2651N111E78
Type		BRX	BRX	BRT
Primary		R1-R2	R1-R2	S1-S3,S2-S4
Input Voltage/Frequency		AC7Vrms 10kHz	AC7Vrms 10kHz	AC3.5Vrms 4kHz
Transformation Ratio		0.5 ± 10%	0.5 ± 5%	0.3 ± 5%
Electrical Error		± 0.5° Max.	± 10' Max.	± 10' Max.
Residual Voltage		50mVrms Max.	20mVrms Max.	—
Phase Shift		+5° Nom.	-5° Max.	—
Impedance	Z _{Ro}	160 Ω Nom.	190 Ω	51+j90 Ω Nom.
	Z _{Rs}	—	—	44+j76 Ω Nom.
	Z _{So}	—	300 Ω	102+j150 Ω Nom.
	Z _{Ss}	130 Ω Nom.	270 Ω	—
Operating Temperature		-55 ~ +155°C	-10 ~ +100°C	-10 ~ +150°C
Max.Operating Speed		100s ⁻¹	83.3s ⁻¹	133.3s ⁻¹
Mass		0.1kg Max.	0.3kg Nom.	0.305kg Nom.
Output Type		Normal	Normal + θ CCW	ER1-R2=K(-ES1-S3SIN θ -ES2-S4COS θ)

Rotor is CCW rotation viewed from mounting flange end.

APPLICATION NOTES

- The supply voltage is a rated value, and a resolver can accept a voltage from 3V to approx. 1.2 times as high as the rating. However, the supply frequency should only be altered within $\pm 5\%$ lest it should affect the accuracy. Electrical parameters largely vary as the frequency varies as shown on the right.
- When a noise source is in vicinity, or when signal transfer distance is long, twisted/shielded pair cables should be used. When a noise still exists on the signals, they should be received by a differential amplifier.
- In BRX resolver, the two output voltages should be connected to the same amount of loads each other, or the voltages will get disproportionate, thus affect the accuracy.
- When an intense magnetic field surrounds a resolver, it may not work properly with its magnetic flux affected.
- When a resolver is used in a high humidity as close to 100% Rh for a long time, waterproof structure should be considered lest its insulation materials should deteriorate.
- All resolvers in the catalog are $1 \times (2 \text{ poles})$ resolvers. For winding modifications to other speeds, please consult us.

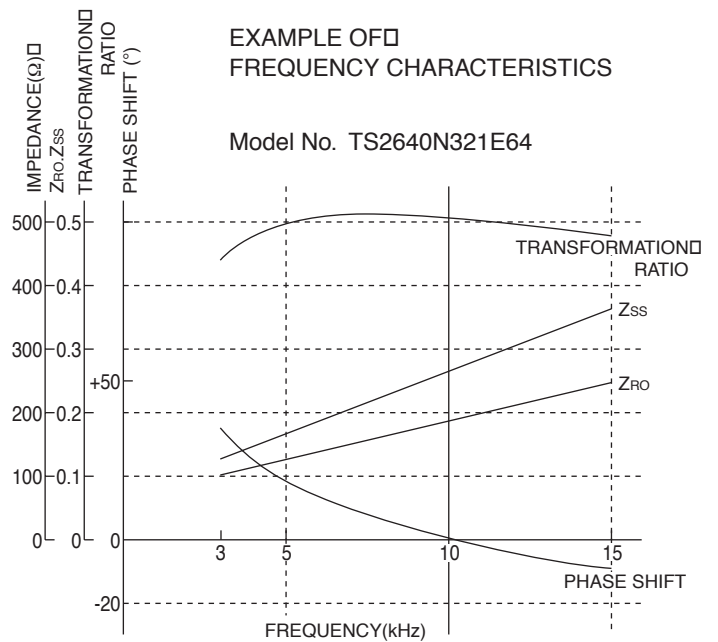

APPLICATIONS

- For Driving Robot Hand and Body.

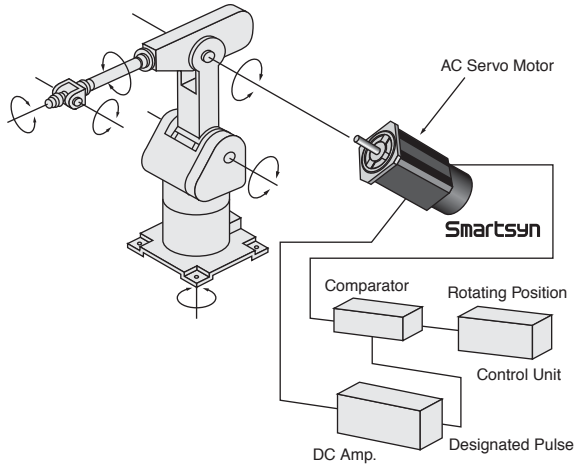

- Applicable to the roller positioning control of rolling mills.

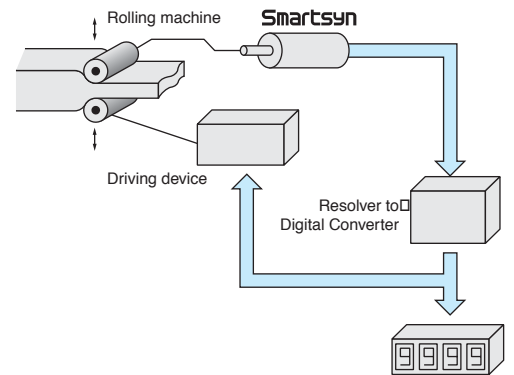

- Smartsyn resolvers which are reliable at high speed are suitable for numerical control systems.

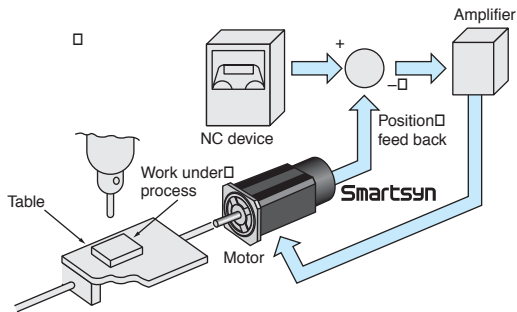

- Detection of traveling position of automatic carrier

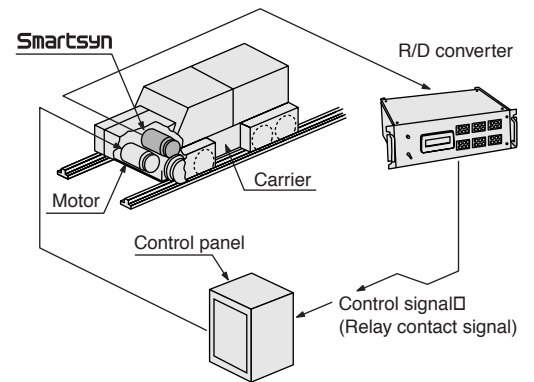



TAMAGAWA TRADING CO.,LTD
A COMPANY OF TAMAGAWA SEIKI CO.,LTD

Headquarters:
1879 OHYASUMI,IIDA,NAGANO PREF,395-8515,JAPAN
PHONE : 0265-21-1800
FAX : 0265-21-1861

SALES OFFICE: :
1020 KEGA,IIDA,NAGANO PREF ,395-8520,JAPAN
PHONE : 0265-56-5423
FAX : 0265-56-5427

TOKYO OFFICE :
3-19-9 SHINKAMATA,OHTA-KU,TOKYO 144-0054,JAPAN
PHONE : 03-3738-3132
FAX : 03-3738-3175

WARRANTY

Tamagawa Seiki warrants that this product is free from defects in material or workmanship under normal use and service for a period of one year from the date of shipment from its factory. This warranty, however, excludes incidental and consequential damages caused by careless use of the product by the user. Even after the warranty period, Tamagawa Seiki offers repair service, with charge, in order to maintain the quality of the product. The MTBF (mean time between failures) of our product is quite long; yet, the predictable failure rate is not zero. The user is advised, therefore, that multiple safety means be incorporated in your system or product so as to prevent any consequential troubles resulting from the failure of our product.

All specifications are subject to change without notice.

URL <http://www.tamagawa-seiki.co.jp>



'04.1

12-1421N6.3,000.2004.1